

TRPGE - - -

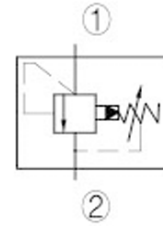
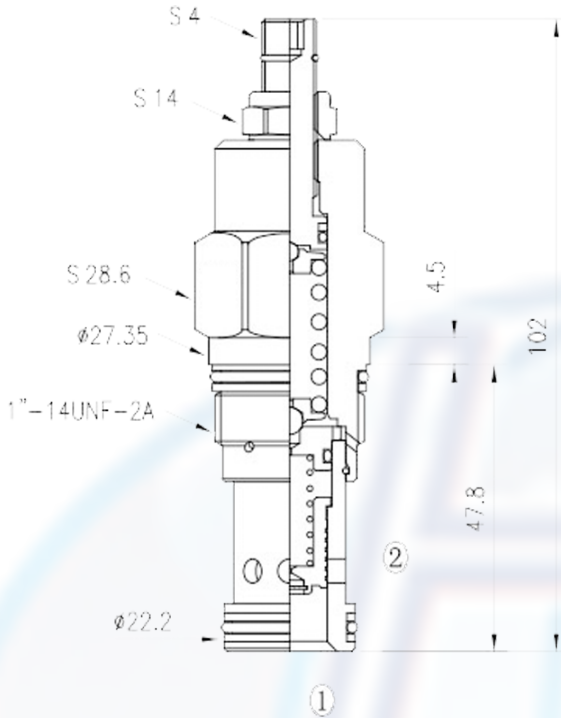

SPECIFICATION:

Max working pressure:	350bar
Flow max:	see performant chart
Internal leakage:	<32.8cc/min/70bar
Response time	10 ms
Filtration of oil:	25m or better
Temperature:	-30 ~ +110°c
Cavity:	T - 10A
Installatin torque:	40 ~ 45Nm

PERFORMANCE

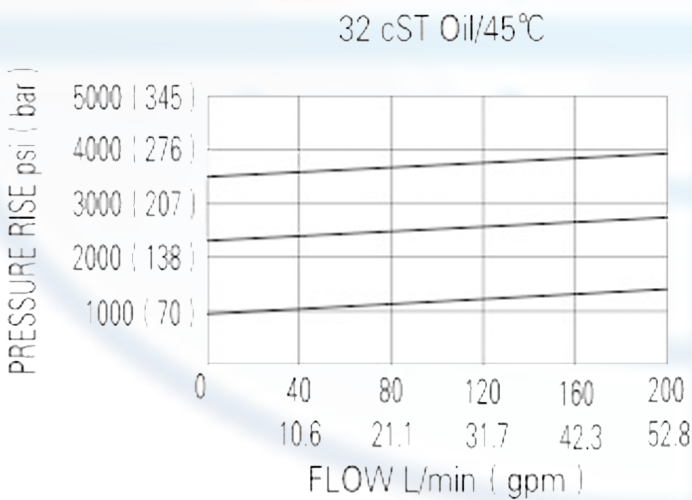

The valve prevents flow from 1 to 2 until pressur at 1 exceeds the set crack pressure and open the pilot section.

the pilot flow creates a pressure differential across the spool which causes the valve to open allowing flow from 1 to 2 protecting the circuit from over pressurization.

to order:

TRPGE - - -

Directly operated relief valves

L = standard screw adjustment

SPRING RANGE:

- A = 7 ~ 210bar, preset : 70bar
- B = 3.5 ~ 105bar, preset : 70bar
- C = 10 ~ 420bar, preset : 70bar
- N = 4 ~ 55bar, preset : 25bar
- Q = 4 ~ 25bar, preset : 14bar
- W = 10 ~ 315bar, preset : 70bar

SEAL KITS:

- N = buna
- V = viton